

# Automatic Tank Gauge Probes

Product Line - India



**GILBARCO**  
**VEEDER-ROOT**

[www.gilbarco.in](http://www.gilbarco.in)

# Automatic Tank Gauges (ATG) Probes

## ► Benefits

### **Continuous level monitoring**

Real time response to tank level changes, accurate delivery reports, no more manual dipping.

### **Water detection**

Detect water before it is dispensed, prevent damage to STP.

### **Multipoint temperature measurement**

Temperature compensated volumes, easier analysis of delivery / temperature variances.

### **Compact size**

Install in limited headroom applications in tank entries as small as 25.4mm

### **In-tank leak detection**

Allows third-party certified tank testing to 0.38 or 0.76 litres per hour precision, without additional cost, at any time.

### **LPG monitoring**

Integrate LPG tanks to central monitoring system for convenience.

### **Special installation kits**

Isolate probe in LPG or aggressive substances for easy installation and maintenance.

### **TLS-RF compatible**

Inventory management and reconciliation, certified tank testing or leak sensor monitoring, without the disruption caused by breaking up the site to install cable ducting.



**Density Mag Plus Probe with HGP Canister**



**Stainless Steel Mag Plus Probe**

# Technical Specifications

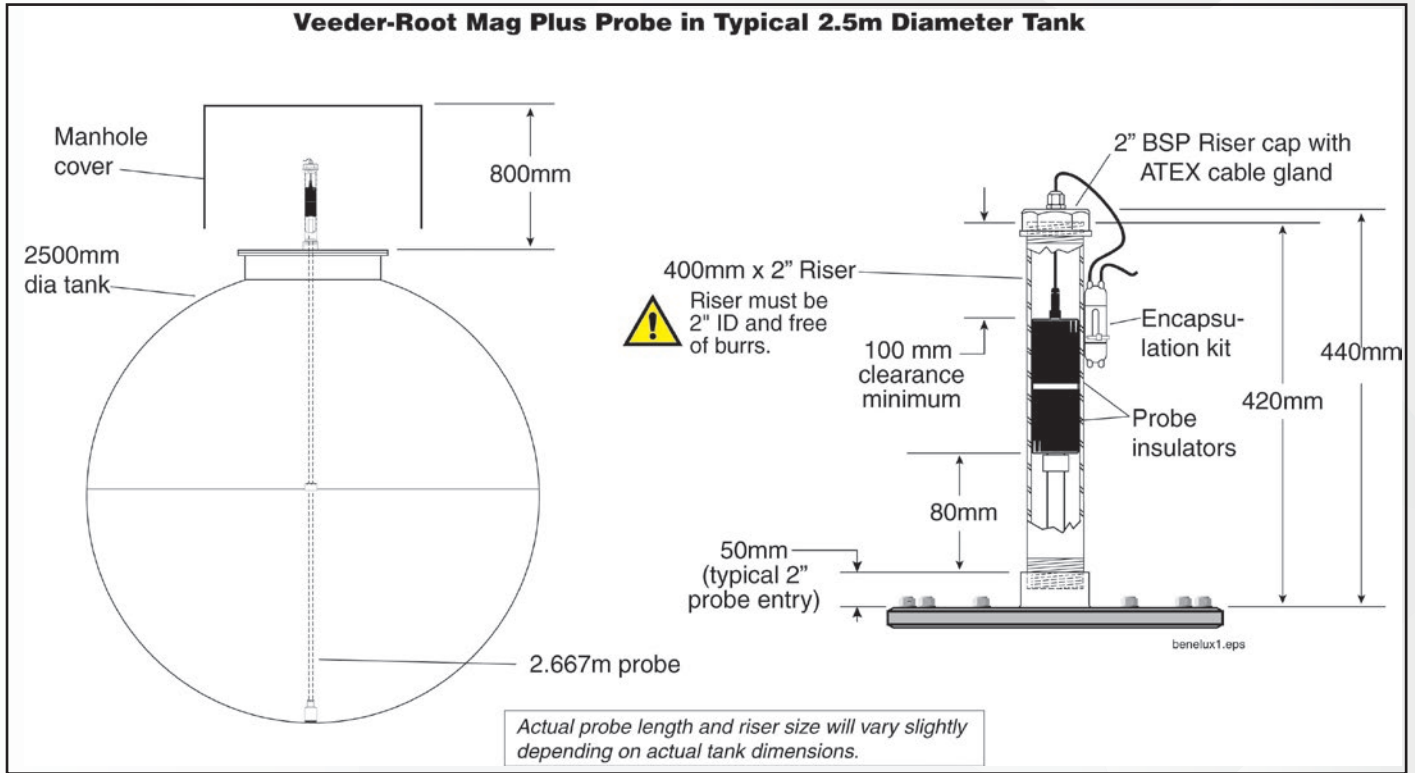

## ATG Specifications

| Probe Type         | Probe Type         | P(D) | P(D)  | P(D)       |
|--------------------|--------------------|------|-------|------------|
| Mag Plus Probe     | 0.1 GPH / 0.38 LPH | 99%  | 1%    | 3 Hours    |
| Mag Plus Probe     | 0.2 GPH / 0.76 LPH | 99%  | <0.1% | 2 Hours    |
| Mag Plus With CSLD | 0.2 GPH / 0.76 LPH | 99%  | <0.1% | Continuous |



**GILBARCO**  
**VEEDER-ROOT**

GILBARCO VEEDER-ROOT INDIA PRIVATE LIMITED | MUMBAI | +91-22-66379132/33  
www.gilbarco.in